

Drop Forged Chain



UNIKING

WWW.UNIKINGCANADA.COM

Drop Forged Chain

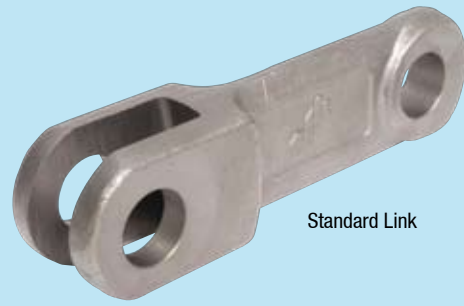

Standard Link

4B's drop forged chain is made of special heat treated alloy steel case hardened to Rockwell C57 - C62 with a ductile core hardness of Rockwell C40.

4B's superior heat treatment technique provides the optimum chain link with a more resilient ductile core for shock resistance, and an extremely hard exterior surface for superior wear resistance.

4B's drop forged chain is backed by an international network of companies with over 120 years of experience, and a global team of engineers and sales professionals that can provide you with practical solutions for all your material handling applications.

Chain Link	4B102NA	4B125NA	4B142NA	4B142HA	4B150NA	4B160NA	4B175NA	4B200NA	4B216NA	4B250NA	4B260NA
Minimum Breaking Load	180 kN 40,400 lb	200 kN 44,900 lb	300 kN 67,500 lb	450 kN 101,000 lb	300 kN 67,500 lb	350 kN 78,700 lb	520 kN 117,500 lb	600 kN 135,000 lb	600 kN 135,000 lb	700 kN 158,000 lb	700 kN 158,000 lb
Case Hardness	Rockwell C57 - C62	Rockwell C57 - C62	Rockwell C57 - C62	Rockwell C57 - C62	Rockwell C57 - C62	Rockwell C57 - C62	Rockwell C57 - C62	Rockwell C57 - C62	Rockwell C57 - C62	Rockwell C57 - C62	Rockwell C57 - C62
Case Depth	0.5 mm	0.6 mm	0.7 mm	0.7 mm	0.7 mm	0.8 mm	1.0 mm	1.0 mm	1.0 mm	1.0 mm	1.0 mm
Core Hardness	Rockwell C40	Rockwell C40	Rockwell C40	Rockwell C40	Rockwell C40	Rockwell C40	Rockwell C40	Rockwell C40	Rockwell C40	Rockwell C40	Rockwell C40
Weight (Per Link)	0.38 kg	0.70 kg	1.08 kg	1.76 kg	1.20 kg	1.30 kg	2.73 kg	2.85 kg	3.66 kg	4.26 kg	5.38 kg
Bolt 'N' Go Compatible	Yes	Yes	Yes	Yes	Yes	Yes	No	Yes	No	No	No

Dimensions

	4B102NA	4B125NA	4B142NA	4B142HA	4B150NA	4B160NA	4B175NA	4B200NA	4B216NA	4B250NA	4B260NA
P	102 mm	125 mm	142 mm	142 mm	150 mm	160 mm	175 mm	200 mm	216 mm	250 mm	260 mm
H	36 mm	35 mm	50 mm	50 mm	49 mm	44.5 mm	60 mm	60 mm	75 mm	75 mm	75 mm
T	7 mm	10 mm	12 mm	16.5 mm	13 mm	13 mm	16 mm	18 mm	19 mm	18 mm	21 mm
W	28 mm	36 mm	42 mm	62 mm	36 mm	42 mm	72 mm	68 mm	59 mm	70 mm	71 mm
M	12 mm	15 mm	18.7 mm	28.5 mm	15 mm	19.5 mm	22 mm	30 mm	26 mm	32 mm	31 mm
D	14 mm	16 mm	25 mm	25 mm	25 mm	20 mm	30 mm	30 mm	35 mm	32 mm	32 mm
F	---	---	---	---	---	---	---	---	---	---	---
E	---	---	---	---	---	---	---	---	---	---	---
B	---	---	---	---	---	---	---	---	---	---	---

- Links and pins are available in all grades of stainless steel.

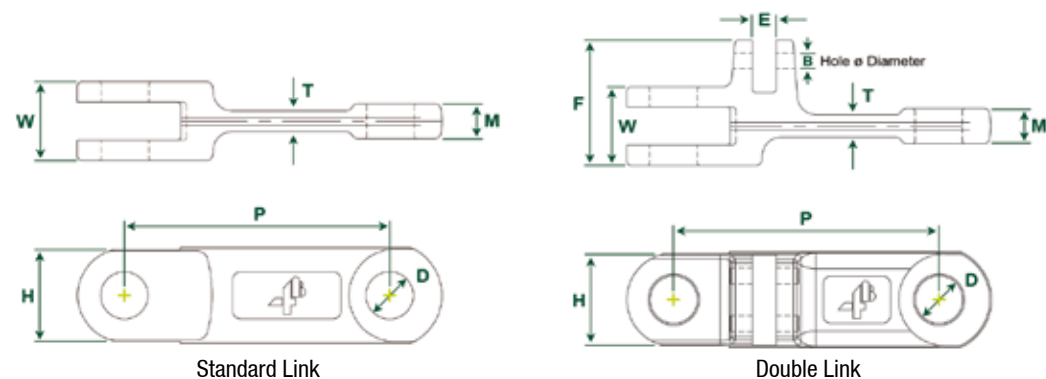

Standard Link

Double Link

UNIKING



UNIKING



Application Photos



Typical Double Strand Chain Application



Feed Mill Application using Bolt 'N' Go Chain with Nylon Flights



UHMW Paddles on "T" Plate Flights - Drive End



UHMW Paddles & Return Buckets - Tail End

Welded Flights and Pins

Typical Welded Flight Attachments

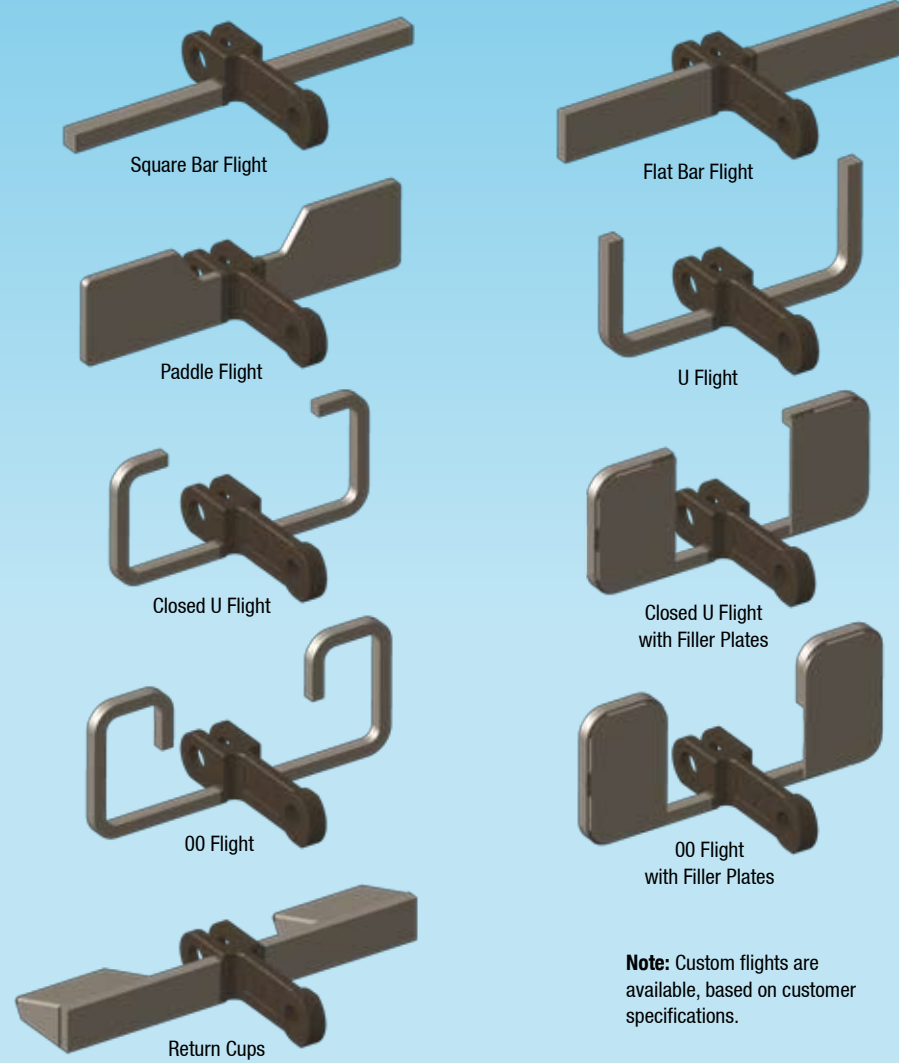

Note: Custom flights are available, based on customer specifications.

Standard Pin Options



Note: Clamps, roll pins, hex bolts and locknuts must not be re-used. Install one time and discard after use.

Bolt ,N,, Go™

The Bolt 'N' Go flight system is a revolutionary assembly method for drop forged. Link and flight assembly is made easy by using a standard bolt and mechanical lock nut with a high strength hollow pin. There are no circlips and no intricate assembly required. There is no welding of flights, no need to remove chain from the conveyor for installation, and no issues with strength. Just bolt the links and the flights together. It's easy, simple and reliable!

U.S. Pat. 7,080,728
Canadian Pat. 2,548,660
Mexican Pat. 272,056
Other Patents Pending

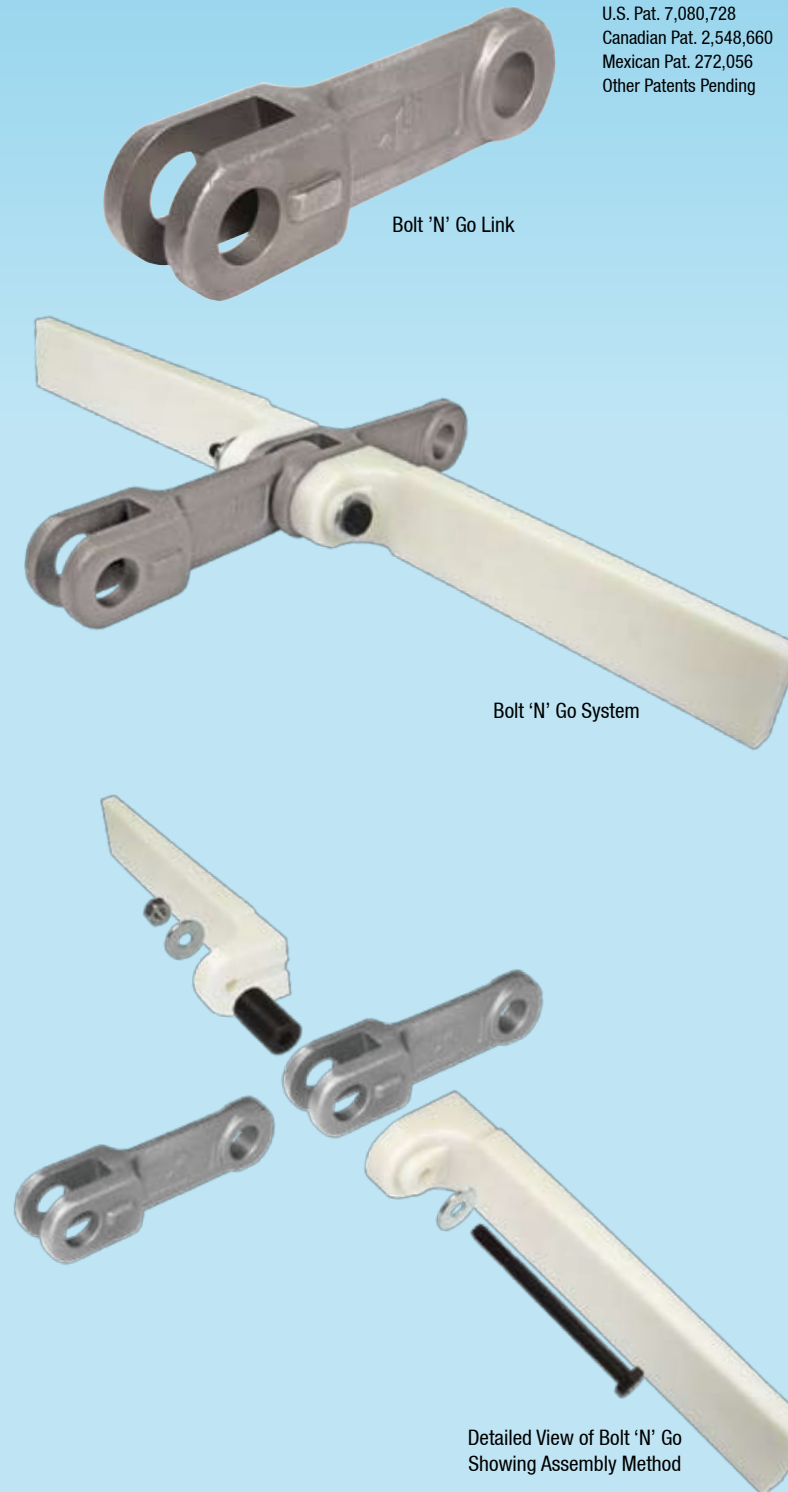

Double & Triple Links

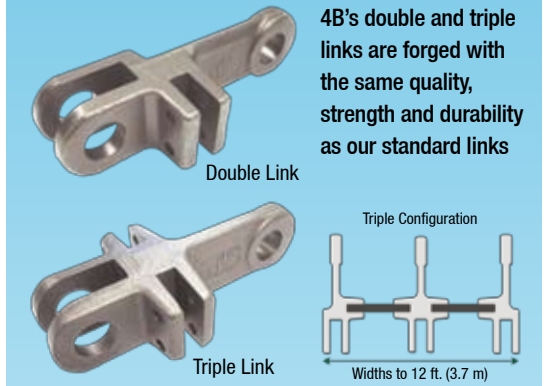

4B142DNA	4B142DHA	4B142TNA	4B142THA	4B175DNA
300 kN 67,500 lb	450 kN 101,000 lb	300 kN 67,500 lb	450 kN 101,500 lb	520 kN 117,500 lb
Rockwell C57 - C62	Rockwell C57 - C62	Rockwell C57 - C62	Rockwell C57 - C62	Rockwell C57 - C62
0.7 mm	0.7 mm	0.7 mm	0.7 mm	1.0 mm
Rockwell C40	Rockwell C40	Rockwell C40	Rockwell C40	Rockwell C40
1.37 kg	2.00 kg	1.67 kg	2.32 kg	3.17 kg
No	No	No	No	No
Dimensions				
142 mm	142 mm	142 mm	142 mm	175 mm
50 mm	50 mm	50 mm	49 mm	60 mm
12 mm	16 mm	12 mm	16 mm	16 mm
42 mm	62 mm	42 mm	62 mm	72 mm
18.7 mm	28 mm	18.7 mm	28.5 mm	22 mm
25 mm	25 mm	25 mm	25 mm	30 mm
67 mm	87 mm	92 mm	112 mm	96 mm
13 mm	13 mm	13 mm	13 mm	17 mm
8.5 mm	8.5 mm	8.5 mm	8.5 mm	10.5 mm

NOTE: Double / triple links use specially designed sprockets and trailers.

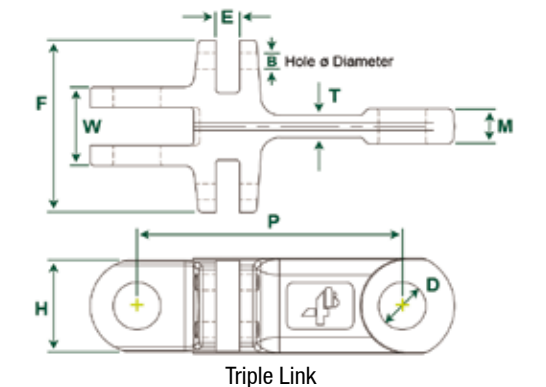



Sprockets and Trailers

4B sprockets and trailers are manufactured from high grade heat treated steel to a minimum hardness of 57 HRC. Each piece is machined to size with appropriate bore and keyway specific to each customer's application. Most sizes are in stock and ready to ship from 4B's extensive inventory.

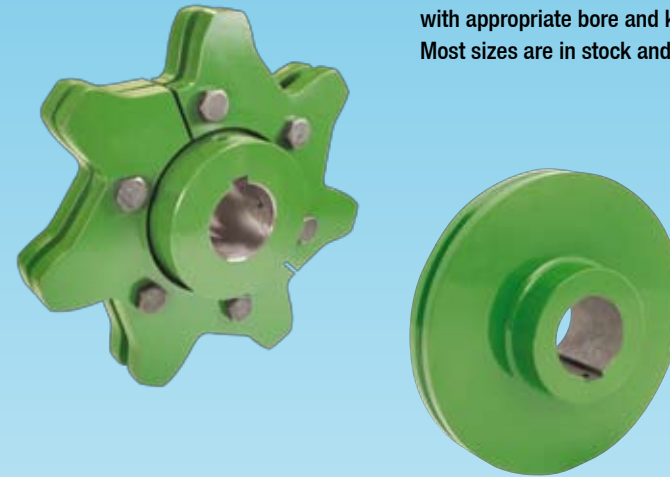

NOW AVAILABLE!
Segmental Star and
Self Cleaning Trailers



Sprocket & Trailer Inventory

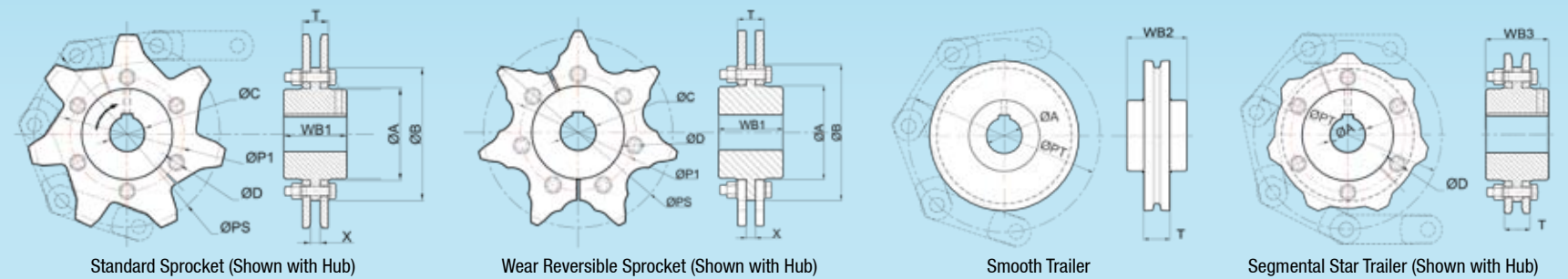

Chain Link	No. of Teeth	Sprockets										Trailers				
		±PS (mm)	±P1 (mm)	±A (mm)	±B (mm)	±C (mm) Max.	±D (mm)	N No. of Holes	T (mm)	X (mm)	WB1 (mm)	Max. Shaft Dia. ±A (mm)	Pitch Circle Dia. ±PT (mm)	Hub Width Dia.* (mm)		Rim Width Dia. T (mm)
														Smooth WB2	Segmental WB3	
4B102NA	6	204.0	---	105.0	135.0	70	---	---	30	10	83	65	204.0	57	83	35
	7	235.1	146.0	108.0	173.0	70	M12	6	30	10	83	65	235.1	57	83	35
	8	266.5	170.0	144.0	196.0	85	M12	6	30	10	83	65	266.5	57	83	35
	9	298.2	200.0	174.0	232.0	105	M12	6	30	10	83	65	298.2	57	83	35
	10	330.1	241.3	179.0	264.0	105	M12	8	30	10	83	65	330.1	57	83	35
4B142NA	6	284.0	168.3	136.5	190.5	85	M12	6	46	16	112	85	284.0	74	112	45
	7	327.3	200.0	162.0	234.0	105	M16	6	46	16	112	85	327.3	74	112	45
	8	371.1	241.3	187.3	282.0	115	M20	8	46	16	127	85	371.1	77	127	45
	9	415.2	285.8	240.0	330.0	150	M20	8	46	16	127	115	415.2	77	127	45
	10	459.5	285.8	240.0	330.0	150	M20	8	46	16	127	115	459.5	77	127	45
	11	504.0	368.3	310.0	419.0	170	M20	8	46	16	150	115	504.0	105	150	45
	12	548.6	415.0	345.0	465.0	170	M20	8	46	16	150	115	548.6	105	150	45
	13	593.4	470.0	380.0	521.0	170	M20	8	46	16	150	115	593.4	120	150	45
4B142HA	7	327.3	200.0	162.0	234.0	105	M16	6	69	19	127	115	327.3	110	127	75
	8	371.1	241.3	187.3	282.0	115	M20	8	69	19	150	115	371.1	110	150	75
	9	415.2	285.8	240.0	330.0	150	M20	8	69	19	150	115	415.2	110	150	75
	10	459.5	285.8	240.0	330.0	150	M20	8	69	19	150	115	459.5	120	150	75
	11	504.0	368.3	310.0	419.0	170	M20	8	69	19	150	140	504.0	120	150	75
	12	548.6	415.0	345.0	465.0	170	M20	8	69	19	150	140	548.6	120	150	75
	13	593.4	470.0	380.0	520.0	170	M20	8	69	19	180	140	593.4	120	150	75
14	638.1	470.0	380.0	546.0	170	M20	10	69	19	180	140	638.1	140	150	75	

NOTE: 2160NA and 260NA sizes are available, contact 4B for more information.
 * Smooth and segmental trailers have different hub widths as noted (WB2 & WB3).
 - 4B offers any bore size to suit your requirements, consult with our engineers for recommended shaft diameter.
 - Specially designed sprockets and stub trailers are required for use with double and triple links, consult a 4B sales engineer for information on your specific application.



Uniking Canada inc.

26 rue des Sesterces
Blainville, Quebec
J7C 6B3 Canada

info@unikingcanada.com
www.unikingcanada.com

Phone : 514-886-5270
Fax : 450-430-1950