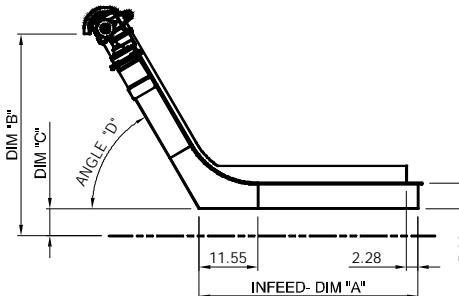
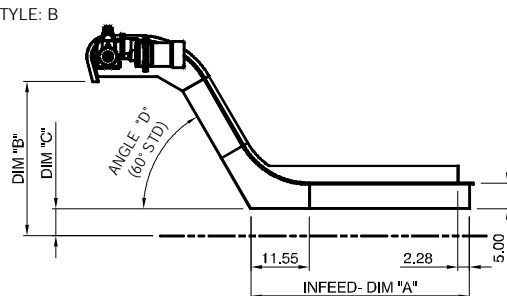
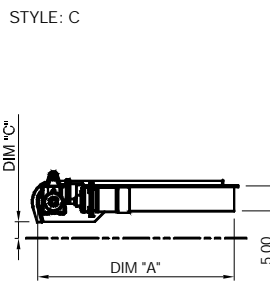
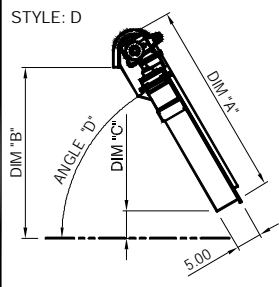
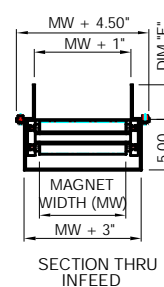
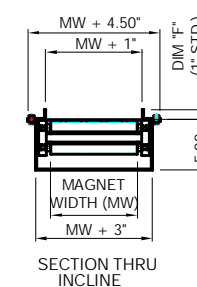

Magnetic Conveyor Quote Sheet

Company Name _____ Contact Name _____

Address _____

Phone _____ Fax _____ Quote Quantity _____

<p>STYLE: A</p> 	<p>STYLE: B</p> 	<p style="text-align: center;"><u>Conveyor Dimensions</u></p> <p>Style: _____</p> <p>Dim "A" _____</p> <p>Dim "B" _____</p> <p>Dim "C" _____</p> <p>Angle "D" _____ (45 & 60 degrees are standard.)</p> <p>Dim "E" _____</p> <p>Dim "F" _____</p>
<p>STYLE: C</p> 	<p>STYLE: D</p> 	<p>SKETCH ALTERNATE INFEED GUIDES AS REQ'D</p> <div style="display: flex; justify-content: space-around;"> <div style="text-align: center;">  <p>SECTION THRU INFEED</p> </div> <div style="text-align: center;">  <p>SECTION THRU INCLINE (STYLES A, B ONLY)</p> </div> </div>
<p>Magnet Width: _____</p> <p>Magnet Centers: _____ (12" is Std.)</p> <p>Cover Thickness:</p> <p><input type="checkbox"/> SS 12ga (0.105")</p> <p><input type="checkbox"/> SS 11ga (0.120")</p> <p><input type="checkbox"/> SS 10ga (0.135")</p> <p><input type="checkbox"/> SS 7ga (0.187")</p> <p><input type="checkbox"/> Manganese (0.187")*</p> <p><input type="checkbox"/> "Rigidized"*</p> <p>Belt Speed:</p> <p><input type="checkbox"/> 10 FPM</p> <p><input type="checkbox"/> 15 FPM</p> <p><input type="checkbox"/> 20 FPM</p>	<p>Voltage:</p> <p><input type="checkbox"/> 110V (single ph.)</p> <p><input type="checkbox"/> 220V (3 ph.)</p> <p><input type="checkbox"/> 440V (3 ph.)</p> <p><input type="checkbox"/> 575V (3 ph.)</p> <p><input type="checkbox"/> Other _____</p> <p>Controls:</p> <p><input type="checkbox"/> Start/Stop-Variable Speed</p> <p><input type="checkbox"/> Emergency Stop</p> <p><input type="checkbox"/> None</p>	<p style="text-align: right;"><u>Material:</u></p> <p>Material to be Conveyed (ferrous) _____ Size: _____</p> <p>Lbs/Hr _____ Liquids Present _____ Type: _____</p> <p>GPM: _____ Hours of operation per day _____</p> <p>Mat'l Temperature: _____ (Cdeg/Fdeg) Impact: (Y/N) _____</p> <div style="background-color: #ffffcc; padding: 5px;"> <p><u>Features:</u></p> <ul style="list-style-type: none"> • Heavy Duty Gearmotor • UHMW Tracks • Oil Bath Lubricated • Regreasable Bearings • 11 Gauge Formed Frame • Fill/Drain Coupling • Machine Enamel Paint, "Master Conveyors Blue" (or provide us with your color) </div> <p><u>Options:</u></p> <p><input type="checkbox"/> Support Leg <input type="checkbox"/> Castors <input type="checkbox"/> Coolant Tank (capacity _____ Gal.)</p> <p><input type="checkbox"/> Filtration System <input type="checkbox"/> "Rigidized" SS Slider Bed* <input type="checkbox"/> Manganese Slider Bed*</p> <p><input type="checkbox"/> Epoxy Paint (must provide specs.) For options not listed contact Master Conveyors Inc.</p>

* Rigidized Slider Bed option must be selected if impact is present or cutting oil is used.

* Manganese Slider Bed option must be selected if heat or large impact is present

Notes _____



MASTER CONVEYORS INC.
 1979 Settingington Drive, Kingsville, Ontario N9Y 2E5
Toll Free: 877-726-9990 519-325-1370 Fax: 519-325-1374
 Web: www.masterconveyors.com Email: sales@masterconveyors.com

1.5" Pitch ChipMaster Quote Sheet

Company Name _____ Contact Name _____

Address _____

Phone _____ Fax _____ Quote Quantity _____

<p>STYLE: A</p>	<p>STYLE: B</p>	<p style="text-align: center;"><u>Conveyor Dimensions</u></p> <p>Style: _____</p> <p>Dim "A" _____</p> <p>Dim "B" _____</p> <p>Dim "C" _____</p> <p>Angle "D" _____ (45 & 60 degrees are standard.)</p> <p>Dim "E" _____</p> <p>Dim "F" _____</p> <p>Dim "G" _____</p>
<p>STYLE: C</p>	<p>STYLE: D</p>	
<p>Belt Width: _____</p> <p><input type="checkbox"/> Plain</p> <p><input type="checkbox"/> Perforated</p> <p><input type="checkbox"/> Pimpled</p> <p><input type="checkbox"/> Perforated/Pimpled</p> <p><input type="checkbox"/> Impact Bars</p> <p>Cleat Centers _____ (3/4" high)</p> <p>Belt Speed:</p> <p><input type="checkbox"/> 10 FPM</p> <p><input type="checkbox"/> 15 FPM</p> <p><input type="checkbox"/> 20 FPM</p> <p><input type="checkbox"/> Other _____</p> <p>Voltage:</p> <p><input type="checkbox"/> 110V (single ph.)</p> <p><input type="checkbox"/> 220V (3 ph.)</p> <p><input type="checkbox"/> 440V (3 ph.)</p> <p><input type="checkbox"/> 575V (3 ph.)</p> <p><input type="checkbox"/> Other _____</p> <p>Controls:</p> <p><input type="checkbox"/> Start/Stop-Variable Speed</p> <p><input type="checkbox"/> Start/Stop/Reverse-Variable Speed</p> <p><input type="checkbox"/> Emergency Stop</p> <p><input type="checkbox"/> Zero Speed Proximity Sensor</p> <p><input type="checkbox"/> None</p>		

Notes _____



MASTER CONVEYORS INC.
 1979 Settingington Drive, Kingsville, Ontario N9Y 2E5
Toll Free: 877-726-9990 519-325-1370 Fax: 519-325-1374
 Web: www.masterconveyors.com Email: sales@masterconveyors.com

2.5" Pitch ChipMaster Quote Sheet

Company Name _____ Contact Name _____

Address _____

Phone _____ Fax _____ Quote Quantity _____

<p>STYLE: A</p>	<p>STYLE: B</p>	<p style="text-align: center;"><u>Conveyor Dimensions</u></p> <p>Style: _____</p> <p>Dim "A" _____</p> <p>Dim "B" _____</p> <p>Dim "C" _____</p> <p>Angle "D" _____ (45 & 60 degrees are standard.)</p> <p>Dim "E" _____</p> <p>Dim "F" _____</p> <p>Dim "G" _____</p>	
<p>STYLE: C</p>	<p>STYLE: D</p>		
<p>Belt Width: _____</p> <p><input type="checkbox"/> Plain</p> <p><input type="checkbox"/> Perforated</p> <p><input type="checkbox"/> Pimpled</p> <p><input type="checkbox"/> Perforated/Pimpled</p> <p><input type="checkbox"/> Impact Bars</p> <p>Cleat Centers _____ (1 1/2" high)</p> <p>Belt Speed:</p> <p><input type="checkbox"/> 12 FPM</p> <p><input type="checkbox"/> 15 FPM</p> <p><input type="checkbox"/> 20 FPM</p> <p><input type="checkbox"/> 30 FPM</p>		<p>Material: Material to be Conveyed _____</p> <p>Size: _____</p> <p>Lbs/Hr _____ Liquids Present _____ Type: _____</p> <p>Features:</p> <p>• Heavy Duty Gearmotor • Friction Disk Torque Limiter • High Carbon Steel Tracks • Regreasable Bearings • 11 Gauge Formed Frame • Incline Cover w/ Chip Suppressor • Machine Enamel Paint, "Master Conveyors Blue" (or provide us with your color specification)</p> <p>Options:</p> <p><input type="checkbox"/> Support Leg <input type="checkbox"/> Castors <input type="checkbox"/> Coolant Tank (capacity _____ Gal.)</p> <p><input type="checkbox"/> Filtration System <input type="checkbox"/> Side Mounted Gear-motor <input type="checkbox"/> Epoxy Paint (must provide specs.) For options not listed contact Master Conveyors Inc.</p>	
<p>Notes _____</p> <p>_____</p> <p>_____</p> <p>_____</p>			



MASTER CONVEYORS INC.
 1979 Settingington Drive, Kingsville, Ontario N9Y 2E5
Toll Free: 877-726-9990 519-325-1370 Fax: 519-325-1374
 Web: www.masterconveyors.com Email: sales@masterconveyors.com